

# Lexmark X925de color MFP



Increase productivity through affordable A3 color

## Model



### Lexmark X925de

The Lexmark X925de color MFP delivers affordable A3 and color functionality for your busy workgroup through easy-to-use features, productivity solutions and a compact design.



Color



Touch screen



Copy



Scan



Fax



Solutions



A3 / 11 x 17



Up to 30 ppm



Duplex



Network

**LEXMARK**  
TM

# Lexmark X925de: key features



## Features that help you optimize your work



### 1) Intuitive color touch screen

The extra large 10.2-inch color touch screen allows you to operate your printer with ease and confidence through smart and intuitive navigation, easy access to workflow solutions and shortcuts, and the ability to preview your documents and print jobs at the device.



### 2) Recirculating automatic document feeder (RADF)

Save time by scanning both sides of your document with robust color-scanning capabilities and an input capacity of up to 100 pages.



### 3) Direct USB

The front USB port allows for convenient walk-up preview, printing and scanning, and is compatible with most printable image file formats.



### 4) Load multiple media types

150-sheet and 250-sheet input trays and a multipurpose feeder come standard, allowing you to load three media types.



### 5) Lexmark solutions

Reduce unnecessary printing and simplify work processes through solution applications preloaded on your device. Choose additional Lexmark solutions to fit your unique workflow needs.



### 6) Eco-friendly features

Print responsibly with easy-to-access features, including Eco-Mode to reduce paper and toner consumption, and the Sleep button to help you save energy.



### 7) Front-loading toner cartridges

Cartridges are conveniently located at the front of the device for easy access.

## Lexmark X925de: overview



### Affordable A3 Color

The Lexmark X925de delivers high quality A3 (11x17) color multifunction performance in an affordable, compact design. Enjoy the benefits of vibrant, professional-quality output on a wide variety of media, allowing you to do more color printing in-house.

- PANTONE® calibration for consistent color tones
- Named Color Replacement for easy color matching
- Supports media up to 11.7 x 48 inches
- Lexmark Color Care Technology to manage color usage and control costs



### Easy and Intuitive

The Lexmark X925de is designed for easy operation and maintenance.

- Extra large, easy to navigate 10.2-inch color touch screen provides audible and tactile feedback to make completing tasks intuitive
- Print and scan preview features help you select documents or specific pages within a document
- Ability to change settings, such as duplex, at the device
- Robust connectivity makes it easy to integrate into almost any network environment
- Sleep button and Hibernate Mode to reduce energy costs
- Device management software available



### Business Productivity

The Lexmark X925de combines high-performance printing, copying, scanning and faxing with time-saving solution applications designed to boost your productivity.

- Print and scan speeds as fast as 30 ppm in both black and color
- Advanced copy functions let you interrupt long print runs to make a quick copy, and proof the first copy set before completing your copy job
- Scan to multiple destinations, including scan to email, scan to FTP, scan to fax, scan to network, and more
- Preloaded applications to drive greater efficiency, and Lexmark Embedded Solutions Framework to further extend the capabilities of the device

## Print Less. Save More.

Print less? This may seem like a surprising message for a company dedicated solely to printing. But when you consider that businesses spend on average up to 6% of their revenue on printing and that active print management can cut office print costs by up to 30%\*, it makes a lot of sense. Lexmark products, solutions and services provide innovative ways to save you time, drive down costs and reduce your impact on the environment. We are committed to helping you print less and save more.



### Solutions

## Save time and money through solutions

Reduce unnecessary printing and simplify work processes with Lexmark solutions. The X925de features Lexmark Embedded Solutions Framework (eSF), our platform that enables you to add a wide range of software applications directly onto the device. Solutions are designed with your productivity in mind, helping you streamline—or even eliminate—paper intensive business processes.

### The following are solutions that come preloaded on the X925de:



#### Forms and Favorites

Eliminate waste and inefficiencies associated with preprinted forms. Store frequently printed forms, marketing materials or other documents online, then print them on demand.



#### Scan to Network

Scan a hardcopy document and route the image to one of 30 predefined personal or public shared network folders.



#### Change Language\*\*

Easily switch the language displayed on the touch screen – 18 languages supported.



#### Showroom

Display a customizable, scrolling slideshow on the color touch screen to promote your business or products, or to communicate important messages to your customers or employees.



#### Card Copy\*\*

Save time and effort in copying identification cards, licenses and insurance cards by automatically scanning, enlarging and printing both sides of a two-sided card onto one side of a sheet of paper.



#### Background and Idle Screen

Change the touch screen background to your corporate logo, a unique message or select one of four available screens.

\* Source: InfoTrends/CapVentures, Network Document Solutions Forecast 2007-2012, Network Document Solutions Consulting Service, August 2008

\*\* Opt-in to Change Language during installation

## Lexmark X925de: highlights

### Make a lasting impression with award-winning color

The documents you print define an important image – yours. That's why Lexmark's color MFPs help businesses be more productive and stand out with vibrant color. With the ability to print professional quality color in-house, you can add instant impact and save costs by virtually eliminating the need to outsource print jobs. Lexmark also offers a host of color-access and control tools to manage costs.



#### Functions



### The right touch

The Lexmark e-Task color touch screen is a key access point to your printer. The extra large customizable 10.2-inch interface gives you the ability to preview thumbnails of documents prior to printing, as well as change print jobs at the device. You can even view, select and print specific pages within a document directly from the touch screen. Its intuitive navigation provides fast access to the functions, shortcuts and workflows you use most, and through the MyMFP feature, you can tailor your device with personal settings. New interactive sensory features provide both tactile and audible feedback, helping to guide you through each operation, confirming a touch has registered and indicating an action is transpiring.



### Protecting your information

From the data traveling through your network to the pages being printed, Lexmark's innovative security controls give you peace of mind that your valuable corporate data is protected at every stage.

- Cutting-edge user authentication and authorization controls, including LDAP, to help protect your device and data
- Card reader option to add an extra layer of security
- Hard disk encryption, protecting sensitive data on the disk drive
- Automatic, scheduled or manual disk wiping
- IPSec, SNMPv3 and 802.1x network security supported
- Security-audit logging to help track and identify security risks



### True Image Always

Lexmark is dedicated to designing and manufacturing products that deliver exceptional quality and reliable performance. Maximize the return on your investment, extend the service life of your Lexmark printing equipment, and make a lasting impression by always insisting on Lexmark Genuine Supplies, Service and Parts. The Lexmark X925de color printer is backed by a one-year base warranty. For further protection against unexpected expenses or downtime, extended warranty offerings are available.

# Lexmark X925de: ordering information

## Lexmark X925de

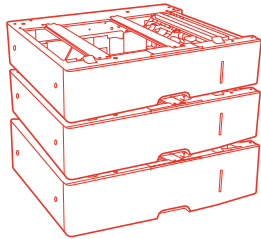
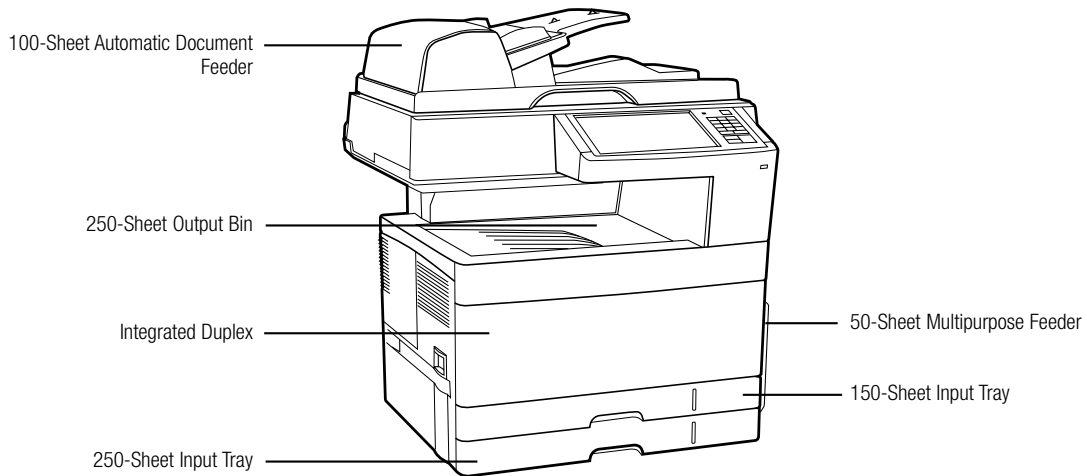

550-Sheet Drawer

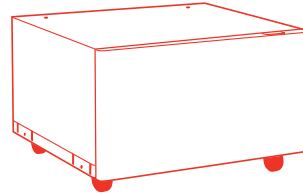

Cabinet with casters + (Use only one 550-Sheet Drawer)



Standard

Optional



### Eco-responsible printing

Printing responsibly means everyone wins – your business, your budget and the environment. Lexmark's award-winning products are designed for ease of use, high quality output and reliable performance, with innovative capabilities that help you minimize the number of cartridges you use over the life of the printer and conserve paper and energy. Our goal is to design, package and deliver innovative products and solutions in an environmentally responsible manner.

# Lexmark X925de: ordering information

## Lexmark X925de

Part #	Model
2420653	Lexmark X925de

Part #	Laser Toner/Print Cartridge
X925H2KG	X925 Black High Yield Toner Cartridge
X925H2CG	X925 Cyan High Yield Toner Cartridge
X925H2MG	X925 Magenta High Yield Toner Cartridge
X925H2YG	X925 Yellow High Yield Toner Cartridge
C925X72G	C925, X925 Black Imaging Unit
C925X73G	C925, X925 Cyan Imaging Unit
C925X74G	C925, X925 Magenta Imaging Unit
C925X75G	C925, X925 Yellow Imaging Unit
C925X76G	C925, X925 Waste Toner Bottle

Part #	Paper Handling
2420030	C925, X925 550-Sheet Drawer

Part #	Furniture
2420031	C925, X925 Cabinet with casters

Part #	Memory Options
1025041	256MB DDR2-DRAM
1025042	512MB DDR2-DRAM
1025043	1024MB DDR2-DRAM
14F0245	256MB Flash Card
30G0287	Arabic Font Card
30G0828	Japanese Font Card
30G0825	Korean Font Card
30G0826	Simplified Chinese Font Card
30G0827	Traditional Chinese Font Card

Part #	Application Solutions
2420043	X925 Card for PRESCRIBE Emulation
2420041	X925 Forms and Bar Code Card
2420042	X925 Card for IPDS
57X9000	Lexmark PrintCryption Card

Part #	Connectivity
27X0025	MarkNet N8250 802.11b/g/n Wireless Print Server
14F0037	MarkNet N8120 Gigabit Ethernet Print Server
14F0042	MarkNet N8130 Fiber Ethernet 100BaseFX, 10BaseFL Print Server
14T0220	MarkNet™ N7020e Gigabit Ethernet Print Server
1021294	USB Cable (2-meter)
14F0000	Parallel 1284-B Interface Card

1021231	Parallel Cable (10-foot)
14F0100	RS-232C Serial Interface Card

Part #	Extended Warranties
2353820	X925 2-Years Total Onsite Service, Next Business Day
2353821	X925 3-Years Total Onsite Service, Next Business Day
2353822	X925 4-Years Total Onsite Service, Next Business Day
2353823	X925 5-Years Total Onsite Service, Next Business Day
2353824	X925 1-Year Onsite Service Renewal, Next Business Day

Part #	User Replaceable Parts
40X6013	C925, X925 Fuser Maintenance Kit 110-120V
40X6011	C925, X925 Transfer Belt and Roll
40X6328	X925 ADF Separator Roll
40X6432	X925 Flatbed Cushion
40X6327	X925 ADF Pick Arm

Part #	Installation Service
2353827	X925 Install, De-Install Service

Part #	Device Embedded App
82S0082	Lexmark Scan to Network Premium

Part #	Software
82S0002	Lexmark Scan to Network

### In the box

Lexmark X925de color multifunction printer, Up to 7,500\*-page color (CMY) toner cartridges, Up to 8,500\*-page black toner cartridge, Black, cyan, magenta, and yellow Imaging units, Software and Documentation CD, Power Cord(s), RJ-11 Phone cable or adapter (country dependent), Setup Guides (network and local attachment), Statement of limited warranty, Lexmark Cartridge Collection Program information

# Lexmark X925de: product specifications

## Lexmark X925de

Printing	
<b>Print Technology</b>	Color LED
<b>Print Speed (Letter, Black): Up to</b>	30 ppm
<b>Print Speed (Letter, Color): Up to</b>	30 ppm
<b>Time to First Page (Black)</b>	As fast as 9 seconds
<b>Time to First Page (Color)</b>	As fast as 11 seconds
<b>Print Resolution, Black</b>	1200 Image Quality, 600 x 600 dpi
<b>Print Resolution, Color</b>	1200 Image Quality, 600 x 600 dpi
<b>Memory, Standard</b>	512 MB
<b>Memory, Maximum</b>	1536 MB
<b>Hard Disk</b>	Included in configuration
<b>Print Noise Level, Operating</b>	53 dBA
<b>Noise Level, Idle</b>	39 dBA
<b>Maximum Monthly Duty Cycle: Up to</b>	200000 pages per month
<b>Recommended Monthly Page Volume</b>	5000 - 10000 pages
Supplies	
<b>Supplies Yield</b> (*Average continuous black or continuous composite CMY declared cartridge yield up to this number of standard pages in accordance with ISO/IEC 19798.)	7,500*-page Color (CMY) High Yield Toner Cartridges, 8,500*-page Black High Yield Toner Cartridge
Copying	
<b>Copy Speed (Letter, Black): Up to</b>	30 cpm
<b>Copy Speed (Letter, Color): Up to</b>	30 cpm
Scanning	
<b>Scanning Resolution</b>	600 X 600 dpi
<b>Reduce / Enlarge Range</b>	25 - 400%
Faxing	
<b>Modem Speed</b>	33.6 Kbps
Paper Handling	
<b>Paper Handling Standard</b>	150-Sheet Input Tray, 250-Sheet Output Bin, Integrated Duplex, 250-Sheet Input Tray, 50-Sheet Multipurpose Feeder
<b>Paper Handling Optional</b>	550-Sheet Drawer
<b>Paper Input Capacity, Standard: Up to</b>	450 pages 20 lb or 75 gsm bond
<b>Paper Input Capacity, Maximum: Up to</b>	2100 pages 20 lb or 75 gsm bond
<b>ADF Paper Input Capacity: Up to</b>	100 pages 20 lb or 75 gsm bond
<b>Media Types Supported</b>	Card Stock, Envelopes, Labels, Plain Paper, Transparencies, Refer to the Card Stock & Label Guide, Banner Paper
General	
<b>Function</b>	Color Copying, Color Faxing, Color Printing, Color Scanning, Color Network Scanning
<b>Product Warranty</b>	1-Year Onsite Service, Next Business Day
<b>Size (in. - H x W x D)</b>	30.35 x 26.46 x 26.30 in.
<b>Weight (lb.)</b>	174.8 lb.

#### Recommended Monthly Page Volume

"Recommended Monthly Page Volume" is a range of pages that helps customers evaluate Lexmark's product offerings based on the average number of pages customers plan to print on the device each month. Lexmark recommends that the number of pages per month be within the stated range for optimum device performance, based on factors including: supplies replacement intervals, paper loading intervals, speed, and typical customer usage.

#### Maximum Monthly Duty Cycle

"Maximum Monthly Duty Cycle" is defined as the maximum number of pages a device could deliver in a month using a multishift operation. This metric provides a comparison of robustness in relation to other Lexmark printers and MFPs.

#### Trademarks

Lexmark and Lexmark with the diamond design are trademarks of Lexmark International, Inc., registered in the United States and/or other countries. All other trademarks are the property of their respective owners. ENERGY STAR® is a U.S. registered mark. Information in this document is subject to change without notice. PANTONE® is a registered trademark of Pantone, Inc. This product features Adobe® Flash® technology. For further information, visit <http://www.adobe.com/software/flash/about/> AirPrint and the AirPrint logo are trademarks of Apple Inc.

Print Less. Save More.

[www.lexmark.com](http://www.lexmark.com)



**LEXMARK**  
TM